

The Orion series of  
Heavy & mining duty horizontal  
slurry pumps

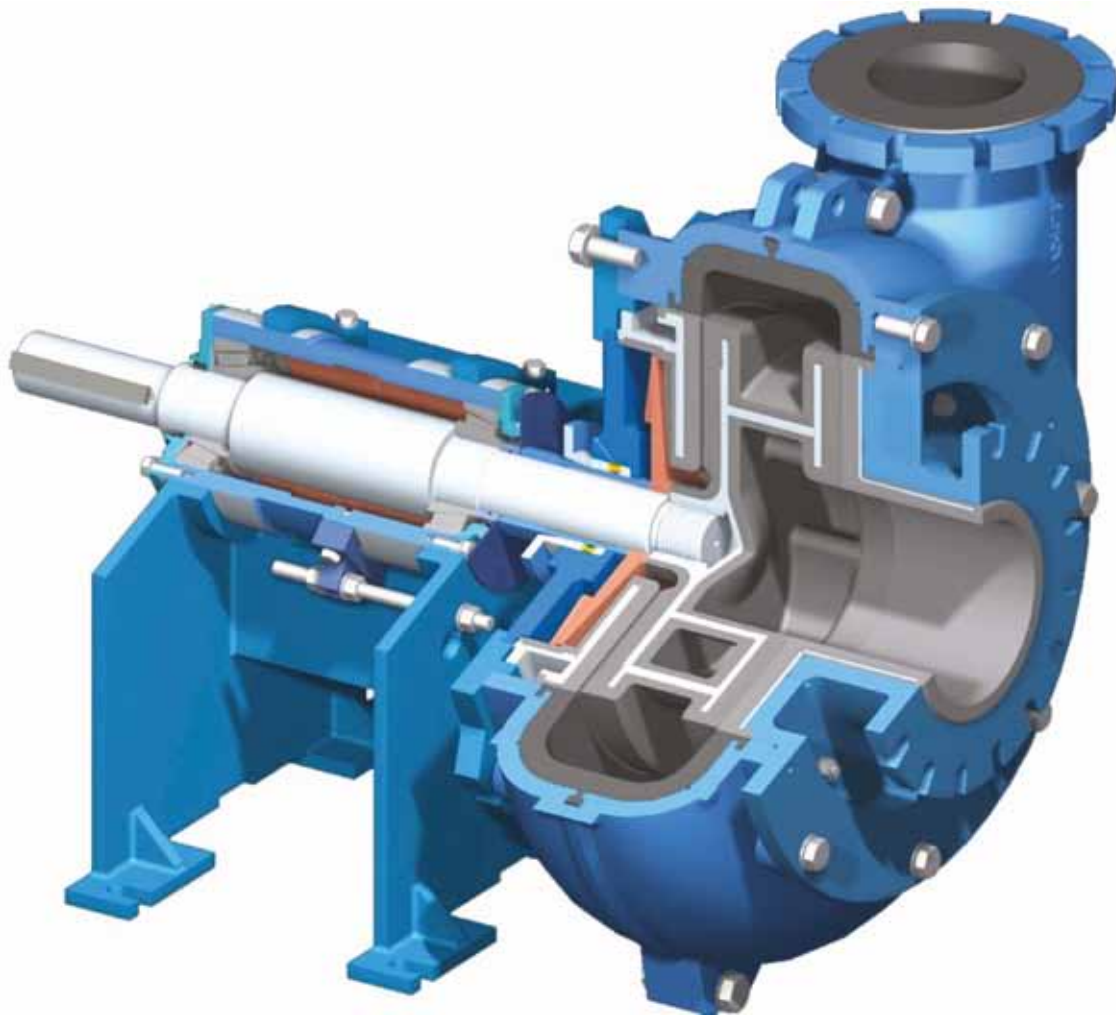



The Orion series of

# Heavy and mining duty rubber lined and me

The Metso heavy (HM, HR) and mining (MR, MM) duty horizontal slurry pumps offer a wide range of world class rubber lined and hard metal slurry pumps for abrasive pumping applications.

**Lowest total cost**

Our focused product development combined with over 60 years of experience from thousands of applications has led to continuous improvements in our products. The benefits to customers are numerous but the most significant is the life time cost saving that will be achieved by using Orion horizontal slurry pumps.

**Low power consumption**

- High efficiency hydraulic design ensures optimal power utilization
- Range optimization ensures operation close to the best efficiency point
- Use of fluid dynamic software to improve pump hydraulic efficiency
- 3-D computer design technology for development of hydraulic and mechanical components

**Long wear life**

- Wear parts of highest quality hard metal, rubber and corrosion-resistant materials
- Robust design with extra thick sections at known points of wear
- Highest quality of wear resistant elastomers developed by Metso

- Interchangeability of hard metal and elastomer parts to provide the best solution for each individual application
- Optional special materials available on request
- Careful application at best efficiency point and selection of wear-resistant material give even wear and long life
- Optional wear clearance double adjustment feature increases wear life

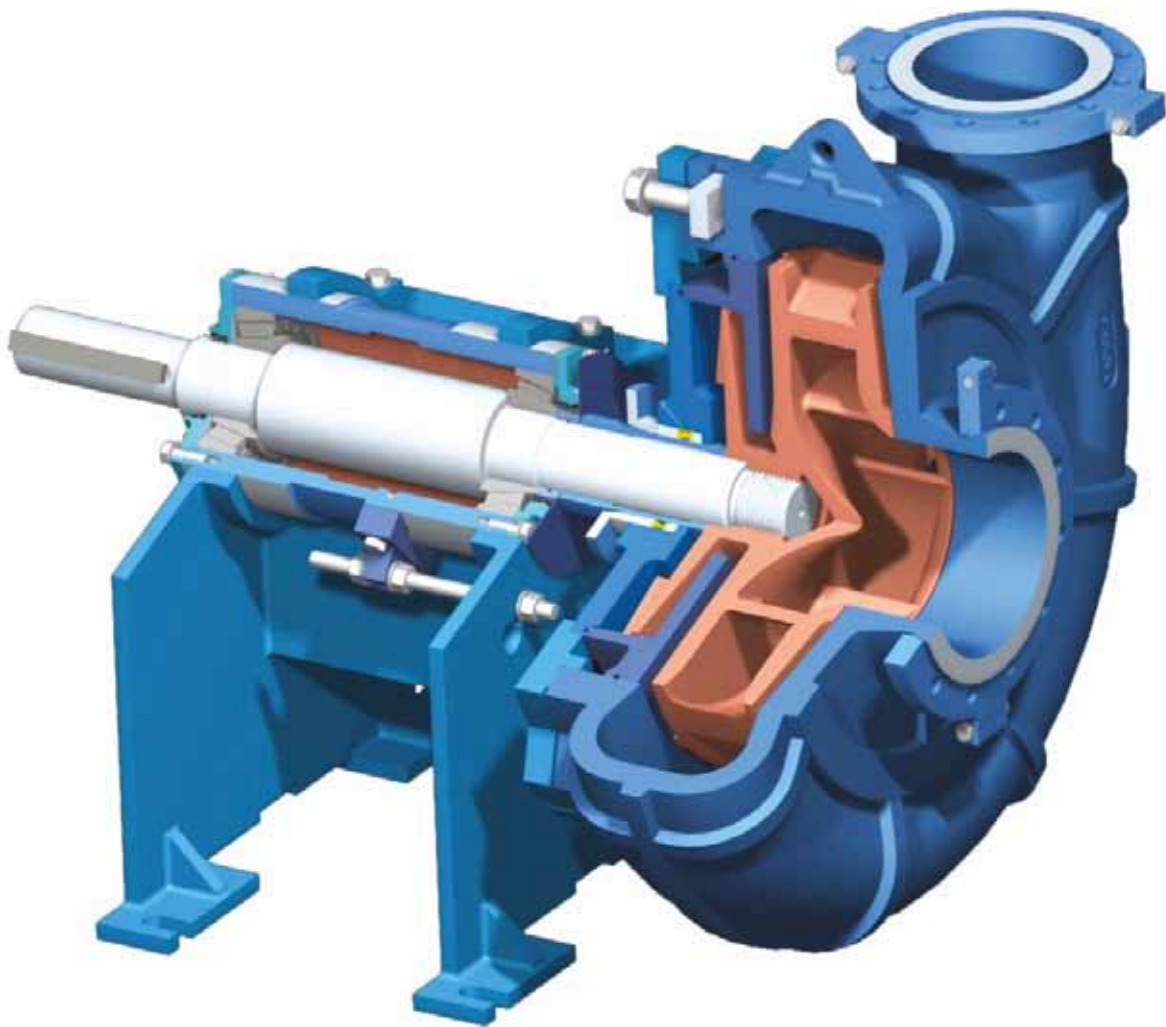

## Horizontal slurry pumps

### Reliability in operation

Specially developed features in our pumps provide trouble-free operation and a minimum downtime improving the cost effectiveness of the operation:

- Oversized high strength alloy steel shaft is carried in heavy duty grease lubricated bearings in a self-contained cartridge assembly
- Double seal arrangement provides positive seal of bearings against contamination
- Proven and reliable gland seal options to meet individual requirements, using expellers, flushed glands or mechanical seals
- Modular design and full interchangeability of parts minimizes stock levels
- Back pull out feature allows ease of inspection and maintenance
- Compact and functional design
- Metso pumps and parts are manufactured under total quality management and all our production units are ISO certified.

### Typical applications

- Mining and mineral processing
- Highly abrasive slurries
- SAG and AG mill discharge recirculation duties
- Cyclone feed
- Mine refuse and tailings
- Industrial processing
- Coal and power plant ash
- Sand and gravel
- Mining duty abrasive slurries
- In-plant slurry transfer pumps
- Pulp & paper
- Lime slurry
- Alumina
- Fertilizer
- Acid Neutralization



**Optional design:**

- Spherical roller bearing
- Cylindrical roller bearing

**Taper roller bearings**

Heavy duty grease lubricated bearings in a sealed cartridge designed for maximum bearing life. Double bearing arrangements available.

**Seals**

Double sealed with V-ring protected lip seal to ensure reliable operation.

**Heavy duty shaft**

Designed for tough services. High power transmission design with reduced impeller overhang for minimum shaft deflection and a maximum pump life.

**Impeller wear clearance adjustment**

Closing front impeller running clearances permits optimum continuous performance of the pump. All adjustments can be made on installed pumps without disassembly. The optional double adjustment frame allows both front and back clearance adjustment.

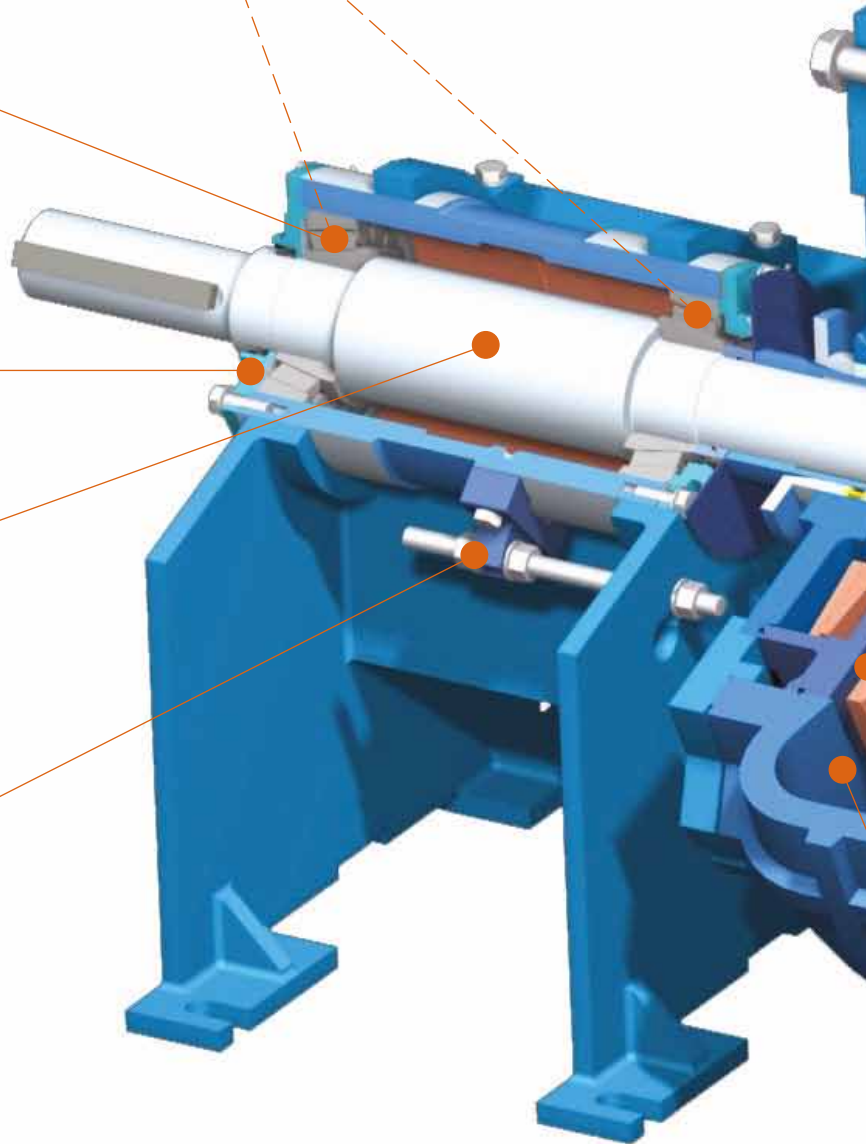

**Standard materials of construction\***

<b>Metal Standard</b>	<b>Casing</b> HighChrome	<b>Impeller</b> HighChrome	<b>Back liner</b> HighChrome	<b>Expeller</b> HighChrome	<b>Expeller ring</b> HighChrome	<b>Shaft sleeve</b> HighChrome	<b>Shaft</b> Carbon steel	<b>Seals</b> Nitrile
<b>Rubber Standard</b>	<b>Case liners</b> Natural rubber	<b>Impeller</b> Natural rubber	<b>Backliner</b> Natural rubber	<b>Expeller</b> HighChrome	<b>Expeller ring</b> Natural rubber	<b>Shaft sleeve</b> HighChrome	<b>Shaft</b> Carbon steel	<b>Seals</b> Nitrile

\*Consult factory for available options

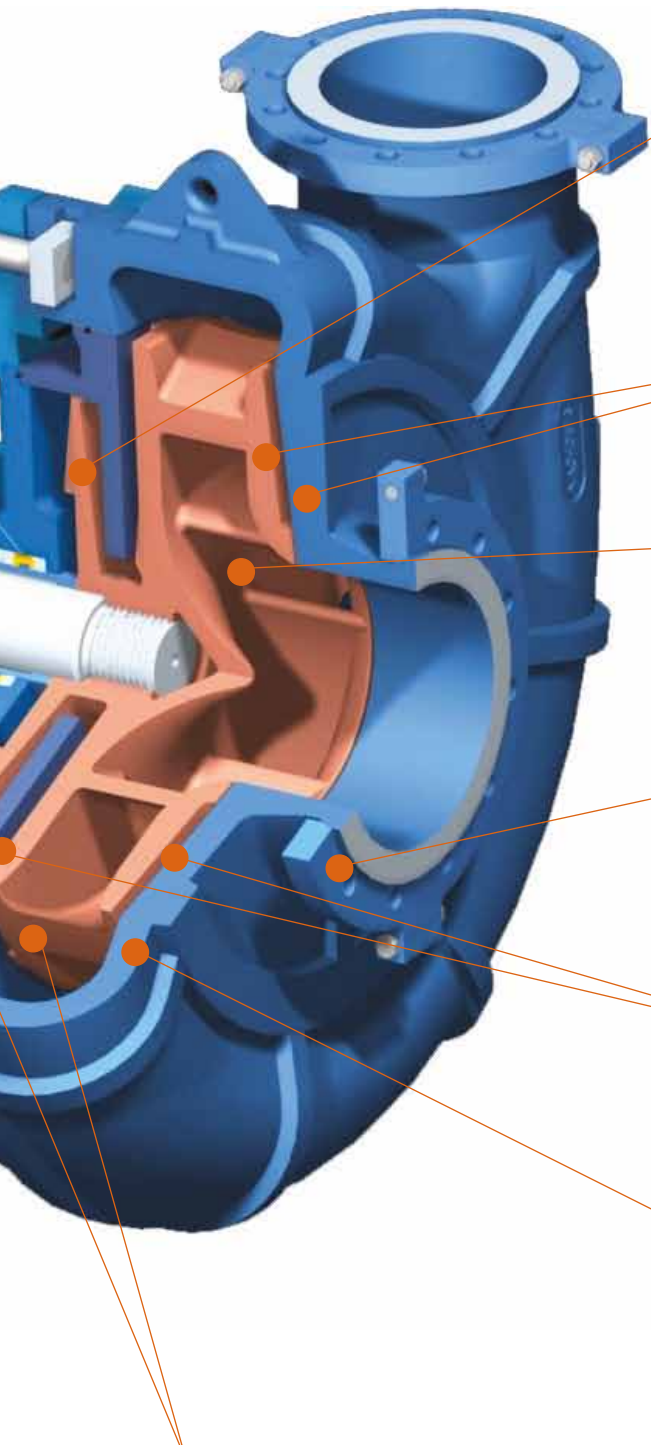

**Centrifugal seal arrangement**

The expeller generates a high head and works in conjunction with expelling back vanes of the impeller to provide a highly effective seal against positive inlet heads without gland leakage. Abrasion resistant materials ensure wear life equivalent to the pump. Three rings of grease-lubricating packing, seal the pump while stationary.

**Even wear design**

Case and impeller are matched for minimum hydraulic turbulence for longer and more equally distributed impeller and case yielding longer wear life.

**Impeller design**

Radial or partial mixed flow main vanes reduce hydraulic shock losses at the suction eye. Large diameters and strategic mass distribution permit high head and high performance at slow speeds without the sacrifice of efficiency.

**ANSI / Metric flanges as required**

Suction and discharge flanges are split on all HM and MM pumps for optional flange configurations, ease of pipe connection and alignment. Rubber lined pumps have slotted flanges to allow most metric or ANSI flanges.

**Front and back expeller vanes**

Optional double adjustment feature permits the use of narrow expelling vanes greatly reducing internal re-circulation with minimal energy consumption.

**Wear resistant castings**

Strict metallurgical control and casting integrity with extra metal at known areas of severe wear.

**Wet ends**

Hard metal and rubber lined wet ends available.





## Shaft sealing options

Combined low flow / full flow stuffing box design can be built for either low or full flow options by changing the arrangement of the lantern ring, packing and flush connections.

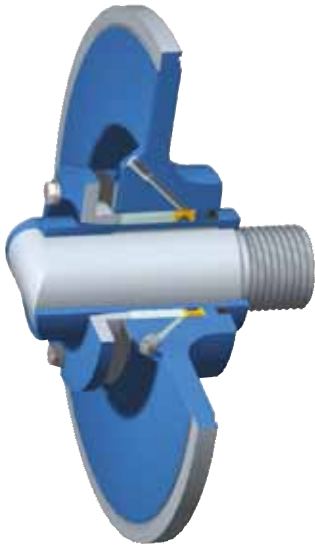

### Full flow

Use for suction conditions not suitable for centrifugal sealing when product dilution is not important. Full flow provides the longest packing wearing life. The lantern ring is placed in the bottom of the stuffing box while the box is protected by a lip seal to avoid damage from temporary concentrate variations.

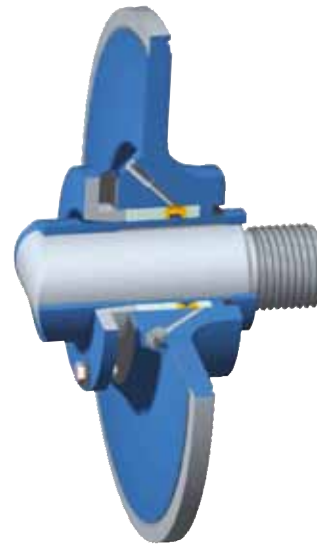

### Low flow

Use for suction conditions not suitable for centrifugal sealing when product dilution needs to be minimized. One ring of packing is placed in front of the lantern ring.

The expeller is not used on flushed seal assemblies.

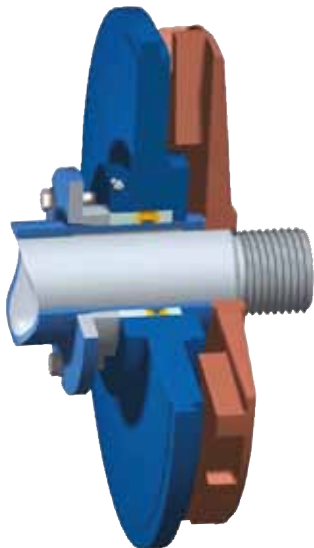

### Standard expeller shaft seal

Used for no product dilution against positive suction head without leakage. The standard pump has a primary high performance hydrodynamic expeller dry seal which seals the shaft when the pump is running. A secondary, packed gland seal stops leakage when the pump is not running.



### Metso slurry mechanical seal

Used for zero stuffing box leakage or product dilution. Available as single slurry type mechanical seal or double mechanical seal with external barrier fluid required. It is possible to use dead-end flush on the double seal.

# Selection of pump size for the heavy duty rubber lined and hard metal slurry pumps

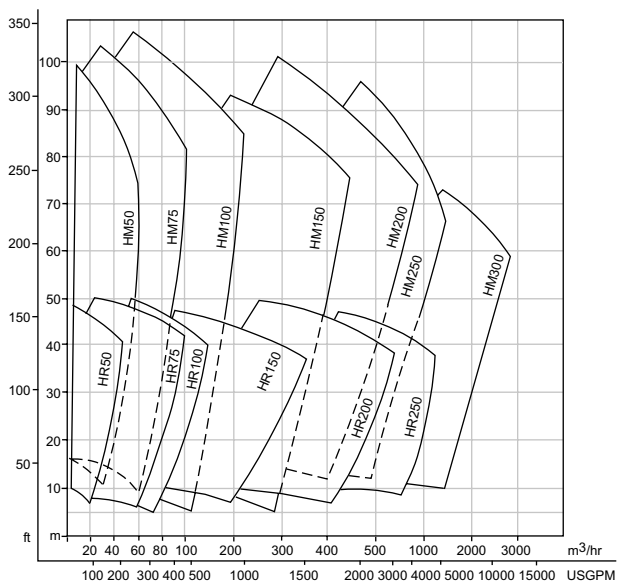

## Pump dimensions

Single adjustment frame

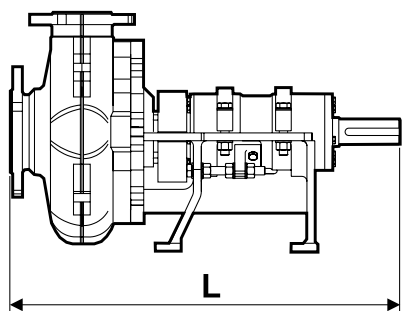

Double adjustment frame

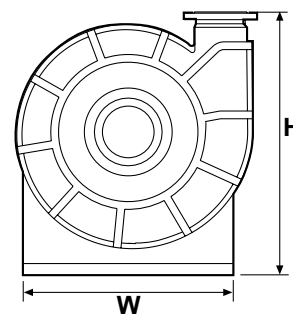
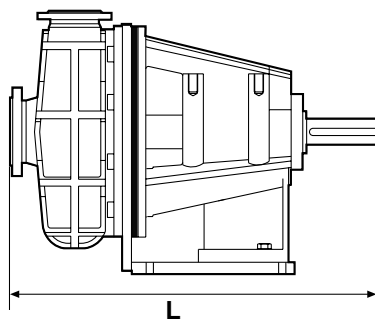

Model	Connection dimensions				General dimensions						Total weight*		Total weight*	
	Inlet		Outlet		H		L		W		Double adjustment		Single adjustment	
	mm	inches	mm	inches	mm	inches	mm	inches	mm	inches	kg	lbs	kg	lbs
HM50 ●	50	2	32	1,5	433	17	713	28	360	14	160	353	136	300
HM75 ●	75	3	50	2	438	17	734	29	360	14	200	441	161	355
HM100 ●	100	4	75	3	505	20	880	35	424	17	320	705	250	551
HM150 ●	150	6	100	4	630	25	1025	40	545	21	550	1213	440	970
HM200	200	8	150	6	855	34	1258	50	686	27	1220	2690	1010	2227
HM250	250	10	200	8	1030	41	1463	58	830	33	2040	4497	1660	3660
HM300	300	12	250	10	1150	45	1591	63	1000	39	2850	6283	1900	4189
HR50	50	2	32	1,5	428	17	709	28	360	14	180	397	126	278
HR75	75	3	50	2	463	18	729	29	360	14	220	485	145	320
HR100	100	4	75	3	555	22	913	36	424	17	330	728	270	595
HR150	150	6	100	4	713	28	1097	43	545	21	630	1389	510	1124
HR200	200	8	150	6	965	38	1295	51	686	27	1250	2756	1065	2348
HR250	250	10	200	8	1125	44	1550	61	830	33	2110	4652	1715	3781

\* Bare shaft pump weight

● These pumps are available with fully recessed induced vortex impeller.



# Selection of pump size for the mining duty rubber lined and hard metal slurry pumps

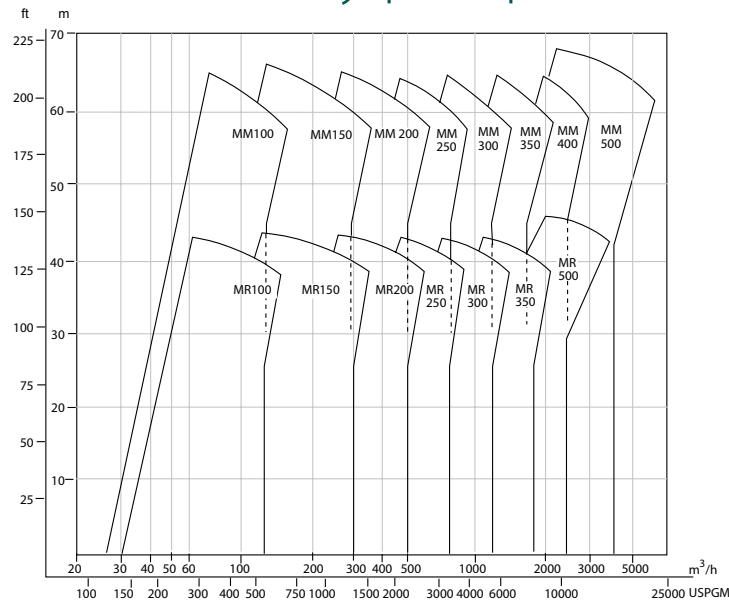

## Pump dimensions

Single adjustment frame

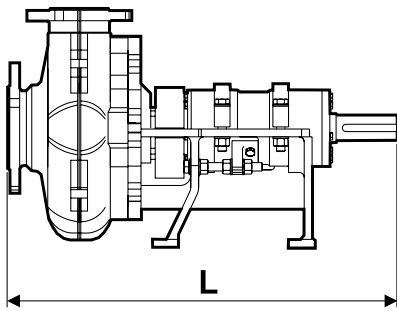

Double adjustment frame

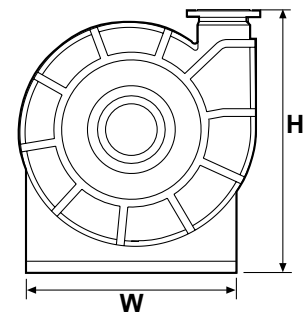
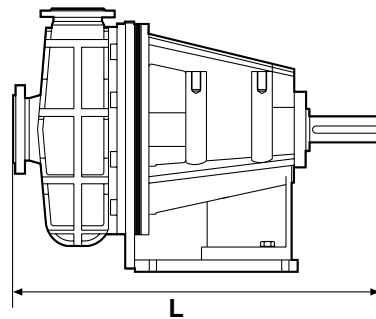

Model	Connection dimensions				General dimensions						Total weight*		Total weight*	
	Inlet		Outlet		H		L		W		Double adjustment		Single adjustment	
	mm	inches	mm	inches	mm	inches	mm	inches	mm	inches	kg	lbs	kg	lbs
MM100 ●	100	4	75	3	454	18	730	29	360	14	230	507	170	375
MM150 ●	150	6	100	4	527	21	889	35	424	17	370	816	275	606
MM200 ●	200	8	150	6	710	28	1 073	42	545	21	650	1 433	525	1 157
MM250	250	10	200	8	885	35	1 245	49	686	27	1 350	2 976	1 095	2 414
MM300	300	12	250	10	1 055	42	1 483	58	830	33	2 150	4 740	1 775	3 913
MM350	350	14	300	12	1 080	43	1 527	60	830	33	2 300	5 071	1 960	4 321
MM400	400	16	350	14	1 250	49	1 620	64	1 000	39	3 000	6 614	2 105	4 641
MM500	500	20	450	18	1 726	68	2 180	86	1 110	44	—	—	5 980	13 184
MM600	600	24	500	20	2 075	81.7	2 352	93	1 204	47	—	—	7 957	17 505
MR100	100	4	75	3	456	18	741	29	360	14	260	573	150	331
MR150	150	6	100	4	507	20	919	36	424	17	420	926	270	595
MR200	200	8	150	6	683	27	1 092	43	545	21	740	1 631	490	1 080
MR250	250	10	200	8	878	35	1 303	51	686	27	1 540	3 395	960	2 116
MR300	300	12	250	10	1 035	41	1 506	59	830	33	2 450	5 401	1 520	3 351
MR350	350	14	300	12	1 257	49	1 665	66	1 000	39	—	—	1 600	5 732
MR500	489	20	438	18	2 064	81	2 689	106	1 204	47	—	—	8 030	17 703

\*Bare shaft pump weight

● These pumps are available with fully recessed induced vortex impeller.

### Standard closed impeller:

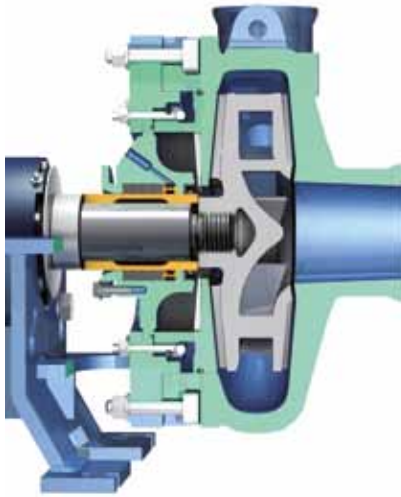

### Induced flow (Vortex) impeller:

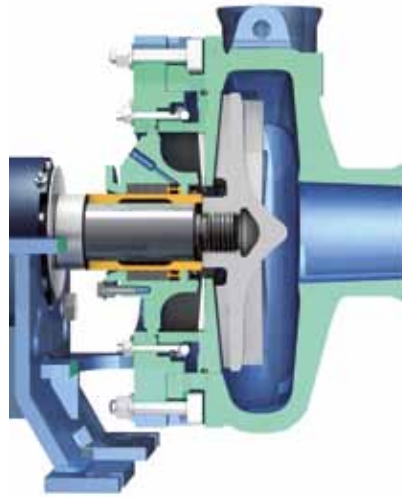

### Fully recessed induced flow (Vortex) impeller:

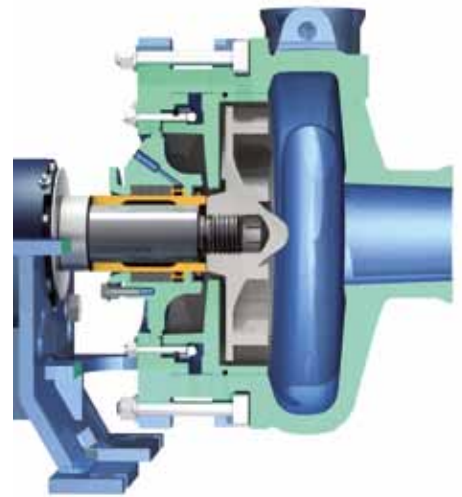

### The Orion series of pumps can also be supplied in a variety of specialty configurations:

- HP - High Pressure - same as HM with heavier duty case for higher pressure.
- HG - Heavy-duty Gravel - suction and discharge flanges are the same size and impeller has less vanes to pass larger material size.
- HT - Heavy-duty Tunneling - same as HM with special 90° elbow cast into the casing.
- HH - High Head - Larger diameter impeller for a given flange sizes.
- HMPT - High Pressure and Temperature - HM pump with a metal liner inside a cast steel casing.

Contact your local Pump Solutions product support team for additional information.

### Available motor arrangements

Direct coupled

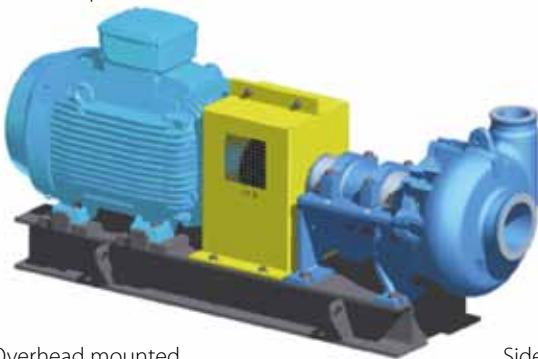

Overhead mounted



Side mounted

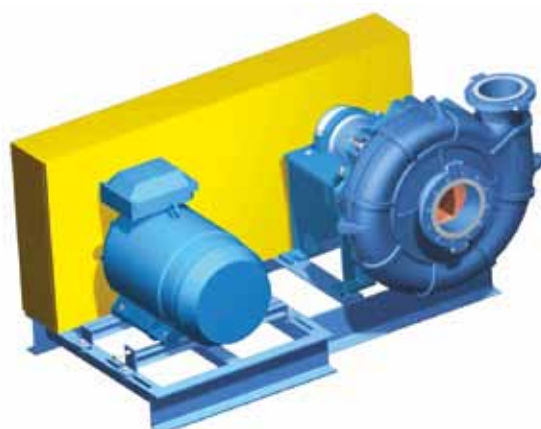

Reverse overhead mounted



## Back and front pull-out design

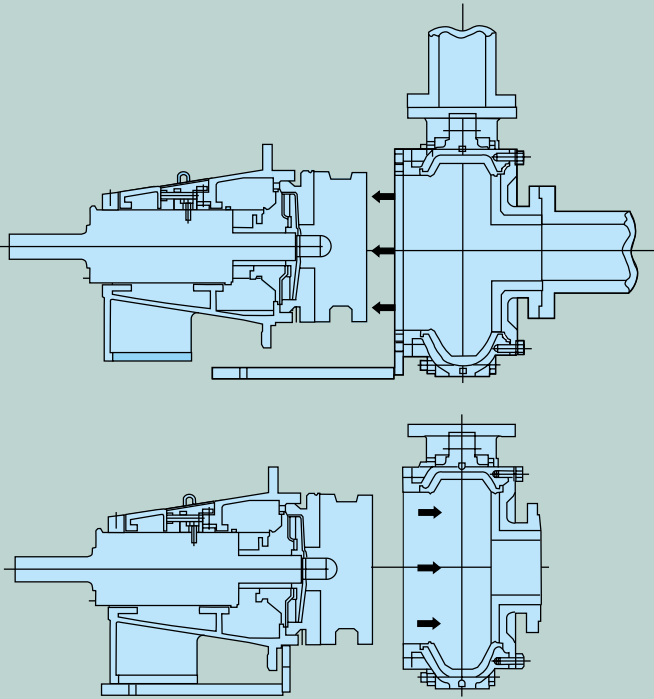

### Back pull-out design

For normal routine inspection or repair, the bearing frame and rotating element can be removed as a unit. Impeller, piping and gland seal component renewal can be carried out rapidly.

### Front pull-out design

For casing only renewal, or if back pull-out is not convenient, the front pull-out feature can be used after pipework removal.

## Optional double adjustment features

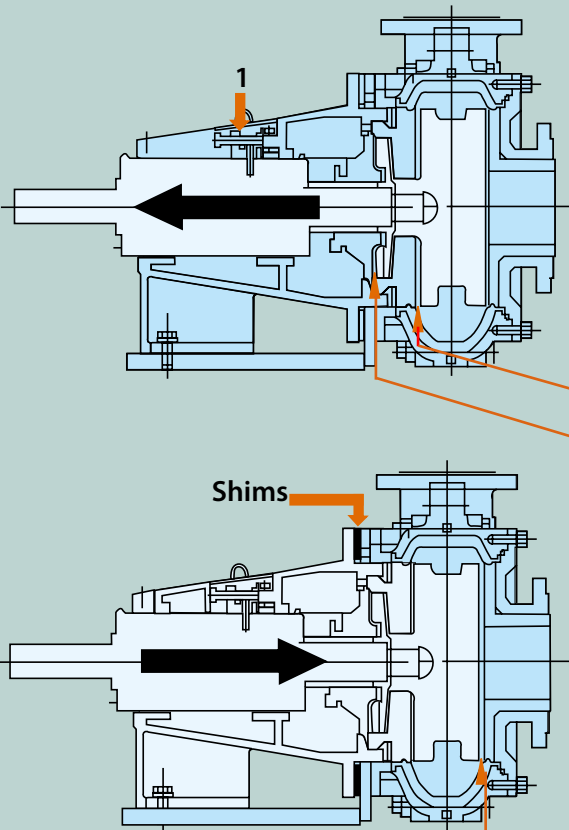

The total impeller wear clearance adjustment is a patented design feature. The procedure of closing the back and front impeller clearances permits constant performance of the pump throughout the normal wear life of all components. This simple operation is illustrated in the two steps shown below and can be performed in minutes on site pump without disassembling the pump.

### Step 1. Adjust impeller back-side clearance

Impeller back clearance and centrifugal seal adjustment is achieved by adjusting the screw on the bearing cylinder housing. The bearing cylinder housing, shaft and impeller move back in order to close the impeller back clearance.

Double adjustment can also be made on low flow, full flow and mechanical seal arrangements.

**Back clearance**

**Centrifugal seal clearance**

### Step 2. Adjust impeller front-side clearance

Impeller front clearance is made by removal of casing half-shims and retightening casing bolts. This also acts as a visual wear indicator. The entire power frame moves forward to close the impeller front clearance.

Once all the shims are removed, the pump can still be operated as a single adjust build.

**Front clearance**



- **Metso Minerals (Sweden) AB**  
Norrängsgatan 2, SE-733 38 Sala, Sweden, Phone: +46 224 570 00, Fax: +46 224 169 50
- **Metso Minerals Industries Inc.**  
4820 Centennial Blvd, Suite 115, Colorado Springs, Co 80919-3351, USA, Phone: +1 719 471 3443, Fax: +1 719 471 4469
- **Metso Minerals Industries Inc.**  
P.O. Box 96, Birmingham, AL 35201, USA, Phone: +1 205 599 6600, Fax: +1 205 599 6623
- **Metso Minerals (South Africa) (Pty) Ltd.**  
Private Bag X2006, Isando, Johannesburg, 1600, South Africa, Phone: +27 11 961 4000, Fax: +27 11 397 2050
- **Metso Minerals (Australia) Ltd.**  
Level 2, 1110 Hay Street, West Perth, WA 6005, Australia, Phone: +61 8 9420 5555, Fax: +61 8 9320 2500
- **Metso Minerals (India) Pvt Ltd**  
1th floor, DLF Building No. 10, Tower A, DLF Cyber City, Phase - III, Gurgaon - 122 002, India, Phone: +91 124 235 1541, Fax: +91 124 235 1601
- **Metso Perú S.A.**  
Calle 5 Nro. 144, Urb. Industrial Vulcano, Ate, Lima 03, Peru, Phone: +51 1 313 4366, Fax: +51 1 349 0913
- **Metso Minerals (Chile) S.A.**  
Av. Los Conquistadores 2758, - Piso 3, Providencia, Santiago, Chile, Phone: +56 2 370 2000, Fax: +56 2 370 2039
- **Metso Brasil Indústria e Comércio Ltda.**  
Av. Independência, 2500 Éden, 18087-101 Sorocaba-SP - Brazil, Phone: +55 15 2102 1300



www.metso.com  
E-mail: minerals.info@metso.com  
Pumps information at  
www.metso.com/pumps